

# TETRANCA

## TC01 Series Compact Frequency Inverter

### MANUAL



# TC01

# TC01 Series Compact VFD

## Simplified Manual V1.0

This manual explains the product's usage and precautions. Please read this manual carefully before installation and use to ensure correct and safe operation of the VFD.

### 1) Safety Precautions

Safety Notice
<ul style="list-style-type: none"> <li>● Installation, operation, and maintenance inspections should be performed by qualified professionals.</li> <li>● In this manual, safety precaution levels are classified as "WARNING" and "CAUTION".</li> </ul> <p>⚠ <b>WARNING:</b> Improper operation creates a hazardous situation that could result in death or serious injury.</p> <p>⚠ <b>CAUTION:</b> Improper operation creates a hazardous situation that could result in minor or moderate injury or property damage.</p>

WARNING
<ul style="list-style-type: none"> <li>● Do not open the front cover or terminal cover while the VFD is powered on. Do not operate the VFD with the front cover or terminal cover removed. Otherwise, you may contact high-voltage terminals and the charging part, resulting in electric shock.</li> <li>● To change wiring or perform inspections, first turn off the power to the VFD. Before the 7-segment display turns off, high voltage remains inside the VFD. Do not touch internal circuits or components.</li> <li>● This VFD must be properly grounded.</li> <li>● Do not operate, touch the heatsink, or connect/disconnect cables with wet hands, as this may cause electric shock.</li> <li>● Do not replace the cooling fan while the power is on, as this is dangerous. Replacing the cooling fan while powered is hazardous.</li> </ul>

CAUTION
<ul style="list-style-type: none"> <li>● The voltage applied to each terminal must only be the voltage specified in the operation manual; otherwise, it may cause malfunction or damage.</li> <li>● Do not perform a withstand voltage test on internal components of the VFD, as the semiconductors used are susceptible to damage from high voltage.</li> <li>● During operation or immediately after power-off, the VFD is hot. Only touch the operator, otherwise burns may occur.</li> <li>● Do not connect terminals incorrectly, as this may cause malfunction or damage.</li> <li>● Do not reverse the polarity (+/-), as this may cause malfunction or damage.</li> <li>● Install the VFD on a non-combustible wall surface without holes (avoid touching the heatsink from the back). Installing directly on or near flammable materials may cause fire.</li> <li>● In case of malfunction, disconnect the power to the VFD. Continuously flowing large currents may cause fire.</li> </ul>

### 2 ) TC01 Series Product Information

#### 2.1 Model Numbering Rule

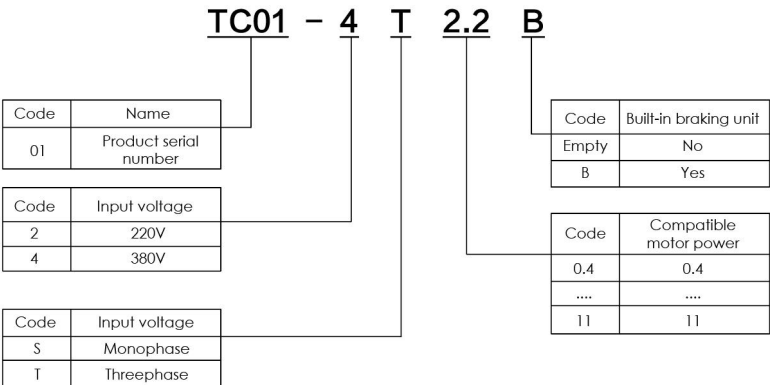

2.1 Model Numbering Rule

## 2.2 TC01 VFD Model and Technical Data

2-1 TC01 VFD Model and Technical Data

VFD Model	Rated Capacity(KVA)	Rated Input Current(A)	Rated Output Current(A)	Applicable Motor(KW)
Single-phase Power Supply 200~240V 50/60Hz				
TC01-2S0.4B	1	5.4	2.3	0.4
TC01-2S0.75B	1.5	8.2	4	0.75
TC01-2S1.5B	3	14	7	1.5
TC01-2S2.2B	4	23	10	2.2
TC01-2S4.0B	5.5	40	16	4.0
Three-phase Power Supply 380~480V 50/60Hz				
TC01-4T0.75B	1.5	3.4	2.1	0.75
TC01-4T1.5B	3	5	3.8	1.5
TC01-4T2.2B	4	5.8	5.1	2.2
TC01-4T3.0B	4.9	8.0	6.8	3.0
TC01-4T4.0B	5.9	10.5	9	4.0
TC01-4T5.5B	8.9	11	13	5.5
TC01-4T7.5B	11	20.5	17	7.5
TC01-4T11B	17	26	25	11

## 2.3 Product and Keyboard Diagrams

### 2.3.1 Outline and Mounting Hole Dimensions

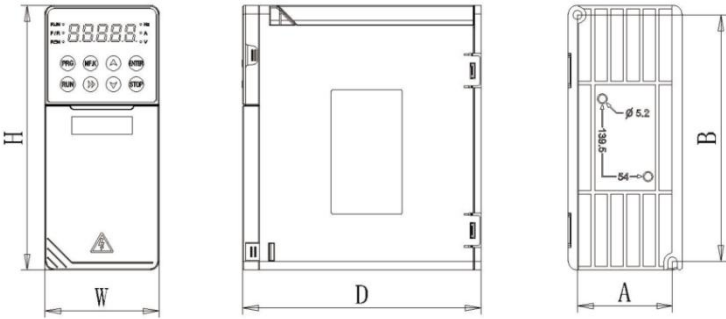

Figure 2-2 Outline Drawing

Table 2-2 Mounting Hole Dimensions

Housing Code	VFD Model	Mounting Hole Position (mm)		Outline Dimensions (mm)				Mounting Hole Diameter (mm)	Weight (Kg)
		A	B	H	H1	W	D		
S1	TC01-2S0.4B	54	139.5	150	/	65	135.5	5.2	
	TC01-2S0.75B								
	TC01-4T0.75B								
	TC01-4T1.5B								
S2	TC01-2S1.5B								
	TC01-2S2.2B								
	TC01-4T2.2B								
	TC01-4T3.0B								
S3	TC01-4T4.0B								
	TC01-4T5.5B								
	TC01-4T7.5B								
	TC01-4T11B								

### 2.3.2 Outline Dimensions of Built-in Keypad KBTC01-1 (without potentiometer)

(Can be externally extended, requires KBTC01-1 keypad cradle)

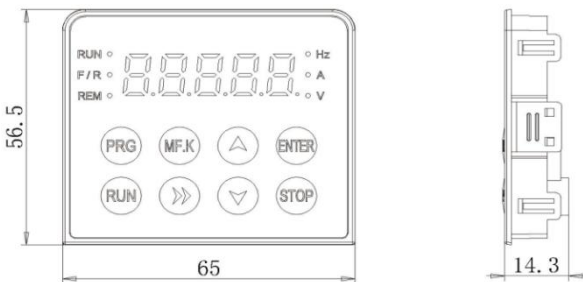

Figure 2-3 Outline Dimension Drawing

**2.3.3 Mounting Cutout Dimensions for External Keypad Cradle KBCTC01-1**  
 (Cutout size: 74.5mm × 58mm)

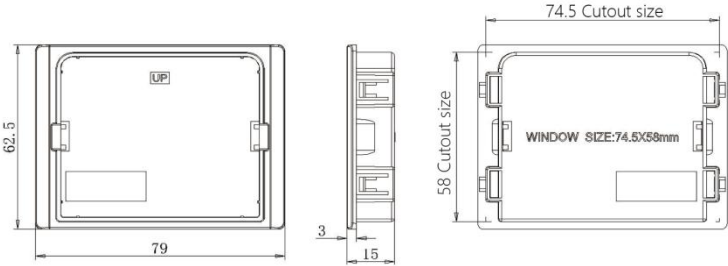

Figure 2-4 Mounting Cutout Dimension Drawing

**2.3.4 Outline Dimensions of External Keypad KBTC01-2 (with analog potentiometer)**  
 (Cutout size: 72\*53.5mm)

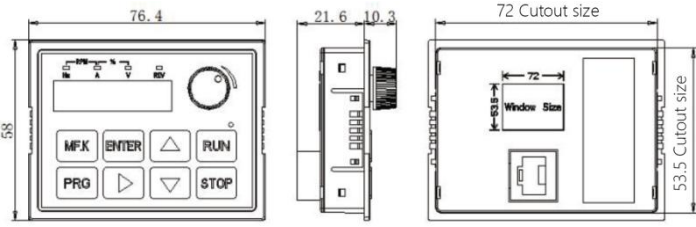

Figure 2-5 Outline Dimension Drawing

**2.4 Typical Wiring Diagram**

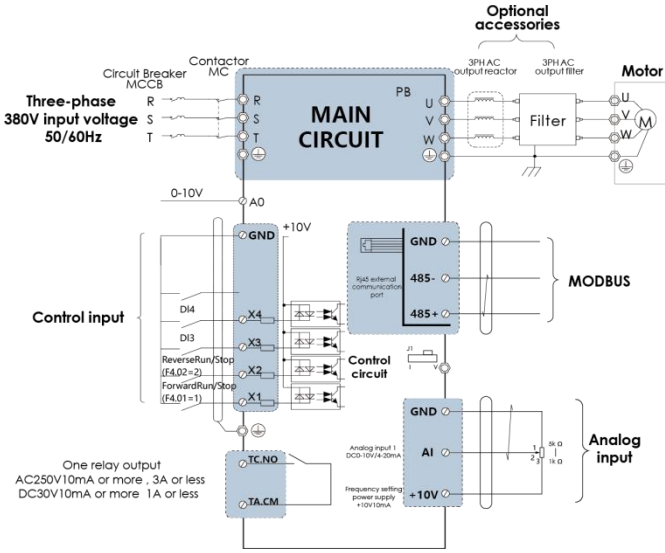

Figure 2-6 Typical Wiring Diagram

**2.5 Control Circuit Terminal Layout**

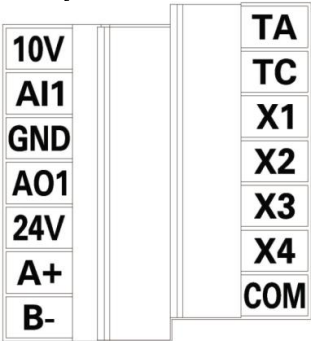

Figure 2-7 Control Circuit Terminal Layout

## 2.6 Control Terminal Function Description:

Table 2-3 Control Terminal Function Description

Category	Terminal Symbol	Terminal Name	Function Description
Power Supply	10V-GND	External +10V power supply	Provides +10V power, max output current: 10mA. Usually used as working power for external potentiometer, potentiometer resistance range: 1kΩ~5kΩ.
Power Supply	24V-COM	External +24V power supply	Provides +24V power, max output current: 100mA.
Analog Input	AI1-GND	Analog Input Terminal 1	Input impedance: 100kΩ for voltage input. For 0~20mA current input, remove the built-in keypad to find the current/voltage jumper for AI1 (position 1 for current, position V for voltage, factory default is V voltage valid). See figure below.
Analog output	AO1-GND	Analog output terminal 1	Outputs 0 to 10V analog quantities. For details, please refer to F5.27 parameters.
Digital Input	X1-COM	Digital Input 1	1. Digital isolation, NPN type input (PNP type requires customization) 2. Input impedance: 5ka
	X2-COM	Digital Input 2	
	X3-COM	Digital Input 3	
	X4-COM	Digital Input 4	
Serial communication port	A+	485 differential signal positive terminal	Standard RS-485 interface, use twisted pair or shielded cable.
	B-	485 differential signal negative terminal	
Relay Output	TA-TC	Normally Open Terminal	Contact rating: AC250V, 3A, COSφ=0.4; DC30V, 1A.
Keypad Interface	CN1	Built-in/External Keypad Interface	8-pin simple header for external keypad.

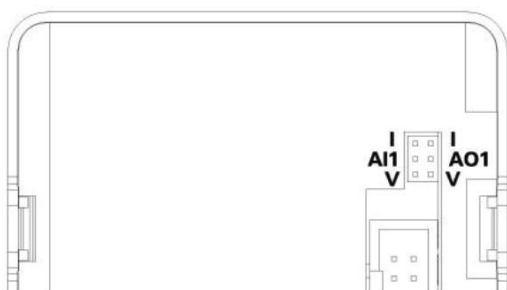

Figure 2-8

### 3 ) Operation and Display Interface Introduction

Using the operation panel, you can modify function parameters, monitor the VFD's working status, and control VFD operation (start, stop), etc. Its outline and functional areas are shown in the figure below:

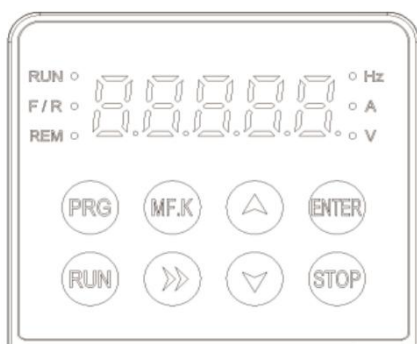









Figure 3-1 Operation Keypad Layout Diagram

## 4 ) Keypad Button Description Table

Table 4-1 Keypad Functions

Button	Name	Function Description
	Program/Exit Key	Enter or exit quick parameter menu.
	Shift/Monitor Key	In stop or run display interface, cyclically select display parameters; when modifying parameters, select the digit to be modified.
	Function/Data Key	Enter menu level by level, confirm parameter settings.
	Multi-function Selection Key	Detailed operation method see description of F0.40 (MF.K key function selection).
	Forward Run Key.	In keypad operation mode, press this key for forward run.
	Stop/Reset Key.	In running state, press to stop operation; in fault alarm state, press to reset. The characteristic of this key is constrained by function code F0.41 (STOP key function).
	Increment Key.	Increment data or function code (continuous press increases increment speed). (For external keypad, UP/DOWN is achieved by turning the digital potentiometer left/right).
	Decrement Key.	Decrement data or function code (continuous press increases decrement speed). (For external keypad, UP/DOWN is achieved by turning the digital potentiometer left/right).

## 5 ) Function Parameter Table

Setting F0.36 to a non-zero value sets a parameter protection password. In function parameter mode and user change parameter mode, the parameter menu can only be entered after entering the correct password. To cancel the password, set F0.36 to "0".

Parameter menus in user-defined parameter mode are not password protected.

Group F and A are basic function parameters, Group L are monitoring function parameters. Symbol descriptions in the function table are as follows: "☆": Indicates the setting value of this parameter can be changed whether the VFD is in stop or run state;

"★": Indicates the setting value of this parameter cannot be changed when the VFD is in running state;

"●": Indicates the value of this parameter is an actual detected/recorded value and cannot be changed;

"\*": Indicates this parameter is a "manufacturer parameter", limited to manufacturer settings, user operation is prohibited.

### 5.1 Basic Function Parameter Summary Table

Table 5-1 Basic Function Parameter Summary Table

Function Code	Name	Setting Range	Factory Default	Change
F0 Basic Function Group				
F0.01	Command Source Selection	0: Operation panel command channel (REMOT LED off) 1: Terminal command channel (REMOT LED on) 2: Communication command channel (REMOT LED flashing)	0	☆
F0.02	Main Frequency Command Selection	0: Digital setting (Preset frequency F0.09, modifiable by UP/DOWN, no power-down memory) 1: Digital setting (Preset frequency F0.09, modifiable by UP/DOWN, power-down memory) 2: All 3: External keypad potentiometer 6: Multi-step command 7: Simple PLC 8: PID 9: Communication reference Note: When F4.01~F4.07 are set to functions 56, 57, 58, and the terminal is active, the multi-step frequency has the highest priority. The multi-step frequency settings are shown in F8.01~F8.07.	0	★
F0.03	Auxiliary Frequency Command Selection	Same as F0.02 (Main frequency command selection)	0	★
F0.04	Frequency Command Addition Method Selection	Units digit: Frequency command selection 0: Main frequency command 1: Main-auxiliary calculation result (operation determined by tens digit) 2: Switch between main frequency command and auxiliary frequency command 3: Switch between main frequency command and main-auxiliary calculation result 4: Switch between auxiliary frequency command and main-auxiliary calculation result Tens digit: Main-auxiliary frequency command operation relationship 0: Main + Aux      1: Main - Aux 2: Max of both      3: Min of both	0	☆
F0.05	Auxiliary Frequency Command Range Selection During Addition	0: Relative to maximum frequency 1: Relative to main frequency command	0	☆
F0.06	Auxiliary Frequency Command Coefficient During Addition	0%~150%	100%	☆

Function Code	Name	Setting Range	Factory Default	Change
	Instruction range			
F0.08	Auxiliary frequency source offset frequency during superposition	0.00Hz~Maximum frequency (F0.13)	0.00Hz	☆
F0.09	Preset frequency	0.00Hz~Maximum frequency (F0.13)	50.00Hz	☆
F0.10	Digital setting frequency stop memory selection	0: No memory 1: Memory	0	☆
F0.11	Frequency command resolution	1: 0.1Hz (The maximum frequency can be adjusted to 3200Hz.) 2: 0.01Hz (The maximum frequency can be adjusted to 3200Hz.)	2	★
F0.12	Runtime frequency command UP/DOWN Reference	0: Operating frequency 1: Set frequency	0	★
F0.13	Maximum frequency	50.00Hz~320Hz	50.00Hz	★
F0.14	Upper limit frequency	Lower frequency limit F0.17 ~ Maximum frequency F0.13	50.00Hz	☆
F0.15	Upper frequency limit command	0: F0.14 set up 1: All 5: Communication given	0	★
F0.16	Upper frequency limit offset	0.00Hz~Maximum frequency F0.13	0.00Hz	☆
F0.17	Lower frequency limit	0.00Hz~Upper limit frequency F0.14	0.00Hz	☆
F0.18	Running mode with set frequency below lower frequency limit	0: Operating at the following frequency limit 1: Shutdown 2: Zero-speed operation	0	☆
F0.19	Carrier frequency	0.5kHz~16.0kHz	Model confirmed	☆
F0.20	Carrier frequency adjusted by temperature	0: No 1: Yes	1	☆
F0.21	Acceleration Time 1	0.00s~650.00s(F0.23=2) 0.0s~6500.0s(F0.23=1) 0s~65000s(F0.23=0)	Model confirmed	☆
F0.22	Deceleration Time 1	0.00s~650.00s(F0.23=2) 0.0s~6500.0s(F0.23=1) 0s~65000s(F0.23=0)	Model confirmed	☆
F0.23	Acceleration/Deceleration Time Unit	0: 1 Second 1: 0.1 Second 2: 0.01 Second	1	★
F0.24	Acceleration/Deceleration Time Reference Frequency	0: Maximum frequency (F0.13) 1: Set frequency 2: 100Hz	0	★
F0.25	Acceleration/Deceleration Method	0: Linear acceleration/deceleration 1: S-curve acceleration/deceleration A 2: S-curve acceleration/deceleration B	0	★
F0.26	S-curve start time percentage	0.0%~ (100.0%-F0.27)	30.0%	★
F0.27	S-curve end time percentage	0.0%~ (100.0%-F0.26)	30.0%	★
F0.28	Jog operation frequency	0.00Hz~Maximum frequency	2.00Hz	☆
F0.29	Jog acceleration time	0.0s~6500.0s	20.0s	☆
F0.30	Jog deceleration time	0.0s~6500.0s	20.0s	☆
F0.31	Terminal inching priority	0: Invalid 1: Valid	0	☆
F0.32	Running direction	0: Same as the set direction 1: Opposite to the set direction	0	☆
F0.33	Anti-reverse control	0: Motor reverse rotation is allowed; 1: Motor reverse rotation is prohibited.	0	☆
F0.34	Function parameter group display and selection	Units digit: Group L display selection 0: Do not display 1: Display Tens digit: Group A display selection 0: Do not display 1: Display	11	☆
F0.36	User password	0~65535	0	☆
F0.37	Function Code Modification Attributes	0: Modifiable 1: Not modifiable (except for F0.36 and F0.37, other parameters cannot be modified)	0	☆
F0.38	Power-On Start Terminal Protection Selection	0: No protection; the inverter runs directly when the run terminal is closed upon power-up. 1: Protection; the inverter does not run when the run terminal is closed upon power-up; it needs to be opened and then closed again to start.	0	☆
F0.39	Undervoltage Point Setting	140.0V~420.0V	Model confirmed	☆
F0.40	MF.K Key Function Selection	0: Invalid 1: Switch between panel and remote command 2: Switch between forward and reverse rotation 3: Forward jog (must be pressed and held to activate; release to stop jogging) 4: Reverse jog (must be pressed and held to activate; release to stop jogging)		
F0.41	STOP/RESET Key Function	0: The STOP/RES key is effective only in keyboard operation mode. 1: The STOP/RES key is effective in all operation modes.	1	☆

Function Code	Name	Setting Range	Factory Default	Change
F0.49	Apply Macro Instructions	0: invalid	0	★
F0.50	Parameter Initialization	0: No operation 01: Restore factory settings, excluding motor parameters and F0.11 02: Clear log information	0	★
F1 Motor 1 Parameters				
F1.00	Motor 1 Control Mode	0: Sensorless Vector Control (SVC) (Applicable only to 3-phase 380V models) 2: V/F Control	2	★
F1.01	Motor Type Selection	0: Common induction motor 1: VFD-duty induction motor	0	★
F1.02	Motor Rated Power	0.1kW~7.5kW	Model confirmed	★
F1.03	Motor Rated Voltage	1V~2000V	Model confirmed	★
F1.04	Motor Rated Current	0.01A~655.35A	Model confirmed	★
F1.05	Motor Rated Frequency	0.01Hz~Maximum frequency	Model confirmed	★
F1.06	Motor Rated Speed	1rpm~6553rpm	Model confirmed	★
F1.07	Asynchronous Motor Stator Resistance	0.001a~65.535a	Self-learning parameters	★
F1.08	Asynchronous Motor Rotor Resistance	0.001a~65.535a	Self-learning parameters	★
F1.09	Asynchronous Motor Leakage Inductance	0.01mH~655.35mH	Self-learning parameters	★
F1.10	Asynchronous Motor Mutual Inductance	0.1mH~6553.5mH	Self-learning parameters	★
F1.11	Asynchronous Motor No-load Current	0.01A~F1.04	Self-learning parameters	★
F1.38	Motor Parameter Auto-tuning Selection	0: No operation 1: Asynchronous motor stationary auto-tuning 2: Asynchronous motor rotating auto-tuning		★
F2 Motor 1 Vector Control Parameters				
F2.00	Speed Loop Proportional Gain 1	1~100	30	☆
F2.01	Speed Loop Integral Time 1	0.01s~10.00s	0.50s	☆
F2.02	Switching Frequency 1	0.00~F2.05	5.00Hz	☆
F2.03	Speed Loop Proportional Gain 2	1~100	20	☆
F2.04	Speed Loop Integral Time 2	0.01s~10.00s	1.00s	☆
F2.05	Switching Frequency 2	F2.02~Maximum frequency	10.00Hz	☆
F2.06	Vector Control Slip Compensation Gain	50%~200%	100%	☆
F2.07	Speed Loop Filter Time Constant	0.000s~0.100s	0.000s	☆
F2.08	Vector Control Over-excitation Gain	0~200	64	☆
F2.09	Torque Upper Limit Source in Speed Control Mode	0: Function code F2.10 setting 1: A11 2: External keyboard potentiometer 5: Communication setpoint 6: MIN (A11, external keyboard potentiometer) 7: MAX (A11, external keyboard potentiometer) Full-scale range of options 1-7 corresponds to F2.10	0	☆
F2.10	Torque Upper Limit Digital Setting in Speed Control Mode	0.0%~200.0%	150.0%	☆
F2.11	Torque Upper Limit Source (Power Generation) under Speed Control Mode	0: Function code P2.12 setting 1: A11 2: External keyboard potentiometer 5: Communication setpoint 6: MIN (A11, external keyboard potentiometer) 7: MAX (A11, external keyboard potentiometer) Full-scale range of options 1-7 corresponds to F2.12	0	☆
F2.12	Torque Upper Limit Digital Setting (Power Generation) under Speed Control Mode	0.0%~200.0%	150.0%	☆
F2.13	Excitation Regulation Proportional Gain	0~60000	2000	☆
F2.14	Excitation Regulation Integral Gain	0~60000	1300	☆
F2.15	Torque Regulation Proportional Gain	0~60000	2000	☆
F2.16	Torque Regulation Integral Gain	0~60000	1300	☆
F2.17	Speed loop integral properties	Units digit: Separate integrals 0: Invalid 1: Valid	0	☆
F2.19	Torque feedforward filter time	1~50	5	★
F2.21	Maximum torque coefficient in the field weakening region	50%~200%	100%	☆
F2.22	Maximum power generation capacity	0.0~200.0%	0.0	☆

Function Code	Name	Setting Range	Factory Default	Change
<b>F2 Motor 1 Vector Control Parameters</b>				
F2.00	Speed Loop Proportional Gain 1	1~100	30	☆
F2.01	Speed Loop Integral Time 1	0.01s~10.00s	0.50s	☆
F2.02	Switching Frequency 1	0.00~F2.05	5.00Hz	☆
F2.03	Speed Loop Proportional Gain 2	1~100	20	☆
F2.04	Speed Loop Integral Time 2	0.01s~10.00s	1.00s	☆
F2.05	Switching Frequency 2	F2.02~Maximum frequency	10.00Hz	☆
F2.06	Vector Control Slip Compensation Gain	50%~200%	100%	☆
F2.07	Speed Loop Filter Time Constant	0.000s~0.100s	0.000s	☆
F2.08	Vector Control Overexcitation Gain	0~200	64	☆
F2.09	Torque Upper Limit Source in Speed Control Mode	0: Function code F2.10 setting 1: All 2: External keyboard potentiometer 5: Communication setpoint 6: MIN (All, external keyboard potentiometer) 7: MAX (All, external keyboard potentiometer) Full-scale range of options 1-7 corresponds to F2.10	0	☆
F2.10	Torque Upper Limit Digital Setting in Speed Control Mode	0.0%~200.0%	150.0%	☆
F2.11	Torque upper limit source (power generation) under speed control mode;	0: Function code P2.12 setting 1: All 2: External keyboard potentiometer 5: Communication setpoint 6: MIN (All, external keyboard potentiometer) 7: MAX (All, external keyboard potentiometer) Full-scale range of options 1-7 corresponds to F2.12	0	☆
F2.12	Torque upper limit digital setting (power generation) under speed control mode.	0.0%~200.0%	150.0%	☆
F2.13	Excitation regulation proportional gain	0~60000	2000	☆
F2.14	Excitation regulation integral gain	0~60000	1300	☆
F2.15	Torque regulation proportional gain	0~60000	2000	☆
F2.16	Torque regulation integral gain	0~60000	1300	☆
F2.17	Speed loop integral properties	Units digit: Separate integrals 0: Invalid 1: Valid	0	☆
F2.19	Torque feedforward filter time	1~50	5	★
F2.21	Maximum torque coefficient in the field weakening region	50%~200%	100%	☆
F2.22	Maximum power generation capacity	0.0~200.0%	0.0	☆
<b>F3 V/F Control Parameter Group</b>				
F3.00	VF Curve Settings	0: Linear V/F 1: Multi-point V/F 10: Full V/F separation mode 11: Partial V/F separation mode	0	★
F3.01	Torque Boost	0.0% : (Automatic torque boost) 0.1%~30.0%	Model confirmed	☆
F3.02	Torque Boost Cutoff Frequency	0.00Hz~Maximum frequency	50.00Hz	★
F3.03	Multi-point VF Frequency Point 3	F3.05~Motor rated frequency (F1.05)	40.00Hz	★
F3.04	Multi-point VF Voltage Point 3	0.0%~100.0%	80.0%	★
F3.05	Multi-point VF Frequency Point 2	F3.07~F3.03	25.00Hz	★
F3.06	Multi-point VF Voltage Point 2	0.0%~100.0%	50.0%	★
F3.07	Multi-point VF Frequency Point 1	0.00Hz~F3.05	10.00Hz	★
F3.08	Multi-point VF Voltage Point 1	0.0%~100.0%	20.0%	★
F3.09	VF Slip Compensation Gain	0.0%~200.0%	0.0%	☆
F3.10	VF Overexcitation Gain	0~600	0	☆
F3.11	VF Oscillation Suppression Gain	0~100	Model confirmed	☆
F3.12	Oscillation Suppression Gain Mode	0: Invalid 3: Valid	3	★

Function Code	Name	Setting Range	Factory Default	Change
F3.13	VF separated voltage source	0: Digital Setting (F3.14) 1: All 5: Multi-segment Instruction 6: Simple PLC 7: PID 8: Communication Input Note: 100.0% corresponds to the motor's rated voltage	0	☆
F3.14	VF separate voltage digital setting	0V ~ Motor rated voltage	0V	☆
F3.15	VF Separation Voltage Acceleration Time	0.0s ~ 1000.0s represents the time from 0V to the motor's rated voltage.	0.0s	☆
F3.16	VF Separation Voltage Deceleration Time	0.0s to 1000.0s represents the time it takes for the motor's rated voltage to drop to 0V.	0.0s	☆
F3.17	VF Separation Shutdown Mode Selection	0: Frequency/voltage decreases to 0 independently 1: Voltage decreases to 0, then frequency decreases.	0	☆
F3.18	Overcurrent Acceleration Operating Current	50~200%	150%	★
F3.19	Overcurrent Acceleration Enable	0: Invalid 1: Valid	1	★
F3.20	Overcurrent Acceleration Suppression Gain	0~100	20	☆
F3.21	Overvoltage stall operating current compensation coefficient	50~200%	50%	★
F3.22	Overvoltage stall operating voltage	650.0V~800.0V	770.0V	★
F3.23	Overvoltage stall enable	0: Invalid 1: Valid	1	★
F3.24	Overvoltage stall suppression frequency gain	0~100	30	☆
F3.25	Overvoltage stall suppression voltage gain	0~100	30	☆
F3.26	Overvoltage stall maximum rise frequency limit	0~50Hz	5Hz	★
F3.27	Slip compensation time constant	0.1~10.0	0.5	★
<b>F4 Digital Input/Output Terminal Function Group</b>				
F4.00	Terminal command method	0: Two-line type 1 1: Two-line type 2 2: Three-line type 1 3: Three-line type 2	0	★
F4.01	X1 Terminal Function Selection	0: No function 1: Forward Run (FWD)	1	★
F4.02	X2 Terminal Function Selection	2: Reverse Run (REV) 3: Three-wire Run Control 4: Forward Jog (FJOG) 5: Reverse Jog (RJOG) 6: Terminal UP 7: Terminal DOWN 8: Free Stop 9: Fault Reset (RESET) 10: Run Pause 11: External Fault Normally Open Input 12: Multi-segment Command Terminal 1 13: Multi-segment Command Terminal 2 14: Multi-segment Command Terminal 3 15: Multi-segment Command Terminal 4 16: Acceleration/Deceleration Time Selection Terminal 1 17: Acceleration/Deceleration Time Selection Terminal 2 18: Frequency Command Switch 19: UP/DOWN Setting Reset (Terminal, Keyboard) 20: Run Command Switch Terminal 1 21: Acceleration/Deceleration Disabled 22: PID Pause 23: PLC Status Reset	4	★
F4.03	X3 Terminal Function Selection		9	★
F4.04	X4 Terminal Function Selection	32: Immediate DC Braking 33: External Fault Normally Closed Input 34: Frequency Modification Enable 35: PID Action Direction Reversal 36: External Stop Terminal 1 37: Run Command Switching Terminal 2 38: PID Integral Pause 39: Main Frequency Command and Preset Frequency Switching 40: Auxiliary Frequency Command and Preset Frequency Switching 43: PID Parameter Switching 44: User-Defined Fault 1 45: User-Defined Fault 2 46: Speed Control/Torque Control Switching 47: Emergency Stop 48: External Stop Terminal 2 49: Deceleration DC Braking 50: Reset Current Run Time 51: Two-Wire/Three-Wire Switching 52: Reverse Reversal Prohibited 56: Multi-Segment Frequency Terminal 1 57: Multi-Segment Frequency Terminal 2 58: Multi-Segment Frequency Terminal 3	12	★

Function Code	Name	Setting Range	Factory Default	Change
F4.11	X Filtering Time	0.000s~1.000s	0.010s	☆
F4.12	Terminal UP/DOWN Change Rate	0.001Hz/s~65.535Hz/s	1.00Hz/s	☆
F4.16	X Terminal Valid Mode Selection 1	0: Active high 1: Active low Units digit: X1 Tens digit: X2 Hundreds digit: X3 Thousands digit: X4	00000	★
F4.18	All Terminal as X Function Selection	0~60	0	★
F4.21	All Terminal as X Valid Mode Selection	0: Active high 1: Active low	000	★
F4.30	Control board relay function selection (TA-TC)	0: No output 1: Inverter running 2: Fault output (fault shutdown) 3: Frequency level detection FDT1 output 4: Frequency reached 5: Zero speed running (no output during shutdown) 6: Motor overload pre-alarm 7: Inverter overload pre-alarm 8: Set value reached 9: Specified value reached 10: Length reached 11: PLC cycle completed 12: Cumulative running time reached 13: Frequency limiting in progress 14: Torque limiting in progress 15: Running ready 17: Upper limit frequency reached 18: Lower limit frequency reached (running related) 19: Undervoltage status output 20: Communication setting 21: FDT2 non-standard output 22: Reserved 23: Zero speed running 2 (output also during shutdown) 24: Cumulative power-on time reached 25: Frequency level detection FDT2 output 26: Frequency 1 reached output 27: Frequency 2 Output reached 28: Current 1 reached output 29: Current 2 reached output 30: Timed output reached 31: All Input exceeded limit 32: Load shedding 33: Reverse operation 34: Zero current state 35: Module temperature reached 36: Output current over-limit 37: Lower limit frequency reached (output even when stopped) 38: Alarm output (continue operation) 39: Motor over-temperature pre-alarm 40: Current running time reached 41: Fault output (for free stop faults, no output under voltage)	2	☆
F4.36	RELAY1 (TA//C) Output Delay Time	0.0s~3600.0s	0.0s	☆
F4.41	Y Output Terminal Active Status Selection 1	0: Positive logic 1: Negative logic Tens digit: RELAY1 (TA/TC)	00000	☆
F4.54	Frequency Detection Value (FDT1)	0.00Hz~Maximum frequency	50.00Hz	☆
F4.55	Frequency Detection Lag (FDT1)	0.0%~100.0% (FDT1 level)	5.0%	☆
F4.56	Frequency reaches detection width	0.0%~100.0% (Maximum frequency)	0.0%	☆
F4.57	Frequency detection value (FDT2)	0.00Hz~Maximum frequency	50.00Hz	☆
F4.58	Frequency detection hysteresis (FDT2)	0.0%~100.0% (FDT2 level)	0.0%	☆
F4.59	Arbitrary arrival frequency detection value 1	0.00Hz~Maximum frequency	50.00Hz	☆
F4.60	Arbitrary arrival frequency detection width 1	0.0%~100.0% Maximum frequency	0.0%	☆
F4.61	Arbitrary arrival frequency detection value 2	0.00Hz~ Maximum frequency	50.00Hz	☆
F4.62	Arbitrary arrival frequency detection width 2	0.0%~100.0% Maximum frequency	0.0%	☆
F4.63	Zero current detection level	0.0%~300.0% 100.0% Corresponding motor rated current	5.0%	☆
F4.64	Zero current detection delay time	0.01s~600.00s	0.10s	☆
F4.65	Output current over-limit value	0.0% (No detection) 0.1%~300.0% (Motor rated current)	200.0%	☆
F4.66	Output current over-limit detection delay time	0.00s~600.00s	0.00s	☆
F4.67	Arbitrary arrival current 1	0.0%~300.0% (Motor rated current)	100.0%	☆
F4.68	Arbitrary arrival current 1 width	0.0%~300.0% (Motor rated current)	0.0%	☆
F4.69	Arbitrary arrival current 2	0.0%~300.0% (Motor rated current)	100.0%	☆
F4.70	Arbitrary arrival current 2 width	0.0%~300.0% (Motor rated current)	0.0%	☆

Function Code	Name	Setting Range	Factory Default	Change
F4.71	All Input Voltage Protection Lower Limit	0.00V~F4.72	3.10V	☆
F4.72	All Input Voltage Protection Upper Limit	F4.71~10.00V	6.80V	☆
<b>F5 Analog Input/Output Function Terminal Group</b>				
F5.01	All Minimum Input	0.00V~F5.03	0.00V	☆
F5.02	All Minimum Input Settings	-100.0%~+100.0%	0.0%	☆
F5.03	All Maximum Input	F5.01~+10.00V	10.00V	☆
F5.04	All Maximum Input Settings	-100.0%~+100.0%	100.0%	☆
F5.05	All Filtering Time	0.00s~10.00s	0.10s	☆
F5.07	External keyboard potentiometer minimum input	0.00V~F5.09	0.00V	☆
F5.08	External keyboard potentiometer minimum input setting	-100.0%~+100.0%	0.0%	☆
F5.09	External keyboard potentiometer maximum input	F5.07~+10.00V	10.00V	☆
F5.10	External keyboard potentiometer maximum input setting	-100.0%~+100.0%	100.0%	☆
F5.11	External keyboard potentiometer filter time	0.00s~10.00s	0.10s	☆
F5.22	AI Curve Selection	Units digit: All curve selection 1: Curve 1 (2 points, see F5.01~F5.04) 2: Curve 2 (2 points, see F5.07~F5.10) Tens digit: External keyboard potentiometer curve selection, same as above	21	☆
F5.23	AI Below Minimum Input Setting Selection	Units digit: All below minimum input setting selection 0: Corresponding to minimum input setting 1: 0.0% Tens digit: External keyboard potentiometer below minimum input setting selection, same as above	000	☆
F5.27	AO1 Output Function Selection	0: Operating Frequency 1: Set Frequency 2: Output Current 3: Output Torque 4: Output Power 5: Output Voltage 9: Panel Potentiometer 10: Length 11: Record Value 12: Communication Setting 13: Motor Speed 14: Output Current (100.0% corresponds to 1000.0A) 15: Output Voltage (100.0% corresponds to 1000.0V)	0	☆
F5.30	AO1 Zero Bias Coefficient	-100.0%~+100.0%	0.0%	☆
F5.31	AO1 Gain	-10.00~+10.00	1.00	☆
<b>F6 Group Start/Stop Control</b>				
F6.00	Starting Method	0: Direct start 2: DC braking start	0	☆
F6.03	Starting Frequency	0.00Hz~10.00Hz	0.00Hz	☆
F6.04	Starting Frequency Holding Time	0.0s~100.0s	0.0s	★
F6.05	Starting DC Braking Current/Pre-excitation Current	0%~100%	50%	★
F6.06	Starting DC Braking Time/Pre-excitation Time	0.0s~100.0s	0.0s	★
F6.07	Stop Method	0: Decelerate and stop; 1: Free stop	0	☆
F6.08	Stop DC Braking Start Frequency	0.00Hz~ Maximum frequency	0.00Hz	☆
F6.09	Stop DC Braking Waiting Time	0.0s~100.0s	0.0s	☆
F6.10	Stop DC Braking Current	0%~100%	50%	☆
F6.11	Stop DC Braking Time	0.0s~100.0s	0.0s	☆
<b>F7 Keyboard and Display Function Group</b>				
F7.02	LED Operation Monitoring Parameter Display Selection 1	0000~1111 Units digit: L0.00 - Operating frequency 1 (Hz) Tens digit: L0.01 - Set frequency (Hz) Hundreds digit: L0.02 - Bus voltage Thousands digit: L0.03 - Output voltage 0: No display 1: Display	0101	☆
F7.03	LED Operation Monitoring Parameter Display Selection 2	0000~1111 Units digit: L0.04 - Output current (A) Tens digit: L0.05 - Output power (kW) Hundreds digit: L0.06 - Output torque (%) Thousands digit: L0.07 - X Input status: 0: No display 1: Display	0001	☆

Function Code	Name	Setting Range	Factory Default	Change
F7.04	LED Operation Monitoring Parameter Display Selection 3	0000~1111 Units digit: L0.08 - Y Output status Tens digit: L0.09 - All Voltage (V) Thousands digit: L0.11 - External keyboard potentiometer voltage (V) 0: No display 1: Display	0000	☆
F7.05	LED operation monitoring parameter display selection 4	0000~1111 Units digit: L0.12 - Count value Tens digit: L0.13 - Length value Hundreds digit: L0.14 - Load speed display Thousands digit: L0.15 - PID setting 0: No display 1: Display	0100	☆
F7.06	LED operation monitoring parameter display selection 5	0000~1111 Units digit: L0.16 - PID feedback Tens digit: L0.17 - PLC stage Thousands digit: L0.19 - Operating frequency 2 (Hz) 0: No display 1: Display	0000	☆
F7.07	LED operation monitoring parameter display selection 6	0000~1111 Units digit: L0.20 - Remaining running time Tens digit: L0.21 - Voltage before All calibration Hundreds digit: L0.22 - Voltage before external keyboard potentiometer calibration (V) 0: No display 1: Display	0000	☆
F7.08	LED operation monitoring parameter display selection 7	0000~1111 Units digit: L0.24 - Motor speed (only applicable to single-phase 220V models) Tens digit: L0.25 - Current power-on time (Hour) Hundreds digit: L0.26 - Current running time (Min) 0: No display 1: Display	0000	☆
F7.09	LED operation monitoring parameter display selection 8	0000~1111 Units digit: L0.28 - Communication setting Hundreds digit: L0.30 - Main frequency X (display) (Hz) Thousands digit: L0.31 - Secondary frequency Y (display) (Hz) 0: No display 1: Display	0000	☆
F7.12	LED Stop Parameter Display Selection 1	0000~1111 Units digit: L0.01 - Set frequency (Hz) Tens digit: L0.02 - Bus voltage (V) Hundreds digit: L0.07 - X Input status Thousands digit: L0.08 - Y Output status 0: No display 1: Display	0011	☆
F7.13	LED Stop Parameter Display Selection 2	0000~1111 Units digit: L0.09 - All Voltage (V) Hundreds digit: L0.11 - External potentiometer voltage (V) Thousands digit: L0.12 - Count value 0: No display 1: Display	0000	☆
F7.14	LED Stop Parameter Display Selection 3	0000~1111 Units digit: L0.13 - Length value Tens digit: L0.17 - PLC stage Hundreds digit: L0.14 - Load speed Thousands digit: L0.15 - PID setting 0: Do not display 1: Display	0000	☆
F7.15	LED Stop Parameter Display Selection 4	0000~1111 Tens digit: L0.16-PID feedback 0: Do not display 1: Display	0000	☆
F7.22	Load speed display coefficient	0.01~200.00	1.00	☆
F7.23	Load speed display decimal places	Units digit: L0.14 Number of decimal points 0: 0 decimal places 1: 1 decimal place 2: 2 decimal places 3: 3 decimal places Tens digit: L0.19/L0.29 Number of decimal points 1: 1 decimal place 2: 2 decimal places	0x20	☆
F7.24	Inverter module Heater temperature	0.0°C~100.0°C	-	●
F7.25	Rectifier module heatsink temperature	0.0°C~100.0°C	-	●
F7.27	Cumulative running time	0h~65535 Hour	-	●
F7.28	Cumulative power-on time	0h~65535 Hour	-	●
F7.29	Product number	-	-	●
F7.30	Functional software version number	-	-	●
F7.31	Cumulative power consumption	0~65535 Spend	-	●
F7.32	Output power correction factor	0.00%~200.00%	100.00%	☆
<b>F8 Auxiliary function terminal group</b>				
F8.00	Forward and reverse dead time	0.0s~3000.0s	0.0s	☆
F8.01	Multiple frequency bands 1	0.00Hz~Maximum frequency	10.00Hz	☆
F8.02	Multiple frequency bands 2	0.00Hz~Maximum frequency	15.00Hz	☆
F8.03	Multiple frequency bands 3	0.00Hz~Maximum frequency	20.00Hz	☆
F8.04	Multiple frequency bands 4	0.00Hz~Maximum frequency	25.00Hz	☆
F8.05	Multiple frequency bands 5	0.00Hz~Maximum frequency	30.00Hz	☆

Function Code	Name	Setting Range	Factory Default	Change
F8.06	Multiple frequency bands 6	0.00Hz~Maximum frequency	35.00Hz	☆
F8.07	Multiple frequency bands 7	0.00Hz~Maximum frequency	40.00Hz	☆
F8.08	Emergency stop deceleration time	0.0s~6500.0s	100.0	☆
F8.10	Speed proportional synchronization control function	0: Invalid 1: Valid	0	☆
F8.11	Synchronization control master-slave selection	0: Master 1: Slave	0	☆
F8.16	Acceleration time 2	0.0s~6500.0s	Model confirmed	☆
F8.17	Deceleration time 2	0.0s~6500.0s	Model confirmed	☆
F8.18	Acceleration time 3	0.0s~6500.0s	Model confirmed	☆
F8.19	Deceleration time 3	0.0s~6500.0s	Model confirmed	☆
F8.20	Acceleration time 4	0.0s~6500.0s	Model confirmed	☆
F8.21	Deceleration time 4	0.0s~6500.0s	Model confirmed	☆
F8.22	Jump frequency 1	0.00Hz~Maximum frequency	0.00Hz	☆
F8.23	Jump frequency 2	0.00Hz~Maximum frequency	0.00Hz	☆
F8.24	Jump frequency amplitude	0.00Hz~Maximum frequency	0.01Hz	☆
F8.25	Drop control	0.00Hz~10.00Hz	0.00Hz	☆
F8.26	Cooling fan control	0: Fan runs during operation 1: Fan runs continuously	0	☆
F8.27	Set cumulative power-on arrival time	0h~65000h	0h	☆
F8.28	Set cumulative running time	0h~65000h	0h	☆
F8.29	Is the jump frequency effective during acceleration and deceleration	0: Invalid 1: Valid	0	☆
F8.30	Frequency switching point between acceleration time 1 and acceleration time 2	0.00Hz~Maximum frequency	0.00Hz	☆
F8.31	Frequency switching point between deceleration time 1 and deceleration time 2	0.00Hz~Maximum frequency	0.00Hz	☆
F8.32	Timer function selection	0: Invalid 1: Valid	0	☆
F8.33	Scheduled operation Time selection	0: F8.34 set up 1: All	0	☆
F8.34	Scheduled run time	0.0Min~6500.0Min	0.0Min	☆
F8.35	Arrival time setting for this run	0.0Min~6500.0Min	0.0Min	☆
F8.38	DPWM switching upper limit frequency	0.00Hz~320.00Hz	12.00Hz	☆
F8.39	PWM modulation method	0: Asynchronous modulation 1: Synchronous modulation	0	☆
F8.40	Dead Zone Compensation Mode Selection	0: No compensation 1: Compensation mode 1 2: Compensation mode 2	1	☆
F8.41	Random PWM Depth	0: Random PWM invalid 1~10: PWM carrier frequency random depth	0	☆
F8.42	Fast Current Limiting Enable	0: Disable 1: Enable	1	☆
F8.43	Overmodulation Coefficient	100%~110%	103	☆
F8.44	SVC Optimization Mode Selection	0: No optimization 1: Optimization mode 1 2: Optimization mode 2	0	☆
F8.45	Low-Frequency Carrier Frequency Limit	0.7~6.0kHz	2.0	☆
F8.46	Overvoltage Point Setting	300.0-2500.0V	Model confirmed	★
<b>F9 group closed-loop PID, constant pressure water supply dedicated parameter group</b>				
F9.00	PID Input Source	0: F9.01 Setting 1: All 2: External Keyboard Potentiometer 5: Communication Setpoint 6: Multi-Segment Instruction Setpoint	0	☆
F9.01	PID Numerical Input	0.0%~100.0%	50.0%	☆
F9.02	PID Feedback Source	0: F9.01 Setting 1: All 2: External Keyboard Potentiometer 5: Communication Setpoint 6: Multi-Segment Instruction Setpoint	0	☆
F9.03	PID Direction of Action	0: Positive effect 1: Negative effect	0	☆

Function Code	Name	Setting Range	Factory Default	Change
F9.04	PID control input feedback (remote pressure gauge range during water supply)	0~65535	1000	☆
F9.05	Proportional Gain KP1	0.0~100.0	20.0	☆
F9.06	Integral Time Ti1	0.01s~10.00s	2.00s	☆
F9.07	Derivative Time Td1	0.000s~10.000s	0.000s	☆
F9.08	PID Reverse Cutoff Frequency	0.00~Maximum frequency	0.00Hz	☆
F9.09	PID Deviation Limit	0.0%~100.0%	0.0%	☆
F9.10	PID Derivative Limit	0.00%~100.00%	0.10%	☆
F9.11	PID Setpoint Change Time	0.00~650.00s	0.00s	☆
F9.12	PID Feedback Filter Time	0.00~60.00s	0.00s	☆
F9.13	PID Output Filter Time	0.00~60.00s	0.00s	☆
F9.15	Proportional Gain KP2	0.0~100.0	20.0	☆
F9.16	Integral Time Ti2	0.01s~10.00s	2.00s	☆
F9.17	Derivative Time Td2	0.000s~10.000s	0.000s	☆
F9.18	PID Parameter Switching Conditions	0: No switching 1: Switching via X terminal 2: Automatic switching based on deviation 3: Automatic switching based on operating frequency	0	☆
F9.19	PID Parameter Switching Deviation 1	0.0%~F9.20	20.0%	☆
F9.20	PID Parameter Switching Deviation 2	F9.19~100.0%	80.0%	☆
F9.21	PID Initial Value	0.0%~100.0%	0.0%	☆
F9.22	PID Initial Value Hold Time	0.00~650.00s	0.00s	☆
F9.23	Maximum positive deviation between two outputs	0.00%~100.00%	1.00%	☆
F9.24	Maximum negative deviation between two outputs	0.00%~100.00%	1.00%	☆
F9.25	PID Integral Attributes	Units digit: Separate the integral 0: Invalid 1: Valid Tens digit: Whether to stop integration after reaching the limit 0: Continue integration 1: Stop integration	00	☆
F9.26	PID Feedback Loss Detection Value	0.0%: No feedback loss is judged 0.1%~100.0%	0.0%	☆
F9.27	PID Feedback Loss Detection Time	0.0s~20.0s	0.0s	☆
F9.28	PID Stop Calculation	0: No calculation during shutdown 1: Calculate during shutdown	0	☆
F9.36	Wake-up Coefficient	Pressure recovery of 0.0% to 100.0% (percentage relative to the target given force) calculated by multiplying F9.36 by F9.01.	0.0%	☆
F9.37	Wake-up Delay Time	0.0s~6500.0s	0.0s	☆
F9.38	Sleep Frequency	0.00Hz ~ Maximum frequency (When the inverter is in sleep mode, the LED digital display will show SLP)	0.00Hz	☆
F9.39	Sleep Delay Time	0.0s~6500.0s	0.0s	☆
F9.40	Water Supply Sleep Tolerance	0.0%~100.0%, This parameter represents the percentage corresponding to a given pressure.	20.0%	☆
<b>FA group multi-segment instruction, simple PLC, swing frequency, fixed length and counting</b>				
FA.00	Multi-segment instruction 0	-100.0%~100.0%	0.0%	☆
FA.01	Multi-segment instruction 1	-100.0%~100.0%	0.0%	☆
FA.02	Multi-segment instruction 2	-100.0%~100.0%	0.0%	☆
FA.03	Multi-segment instruction 3	-100.0%~100.0%	0.0%	☆
FA.04	Multi-segment instruction 4	-100.0%~100.0%	0.0%	☆
FA.05	Multi-segment instruction 5	-100.0%~100.0%	0.0%	☆
FA.06	Multi-segment instruction 6	-100.0%~100.0%	0.0%	☆
FA.07	Multi-segment instruction 7	-100.0%~100.0%	0.0%	☆
FA.08	Multi-segment instruction 8	-100.0%~100.0%	0.0%	☆
FA.09	Multi-segment instruction 9	-100.0%~100.0%	0.0%	☆
FA.10	Multi-segment instruction 10	-100.0%~100.0%	0.0%	☆
FA.11	Multi-segment instruction 11	-100.0%~100.0%	0.0%	☆
FA.12	Multi-segment instruction 12	-100.0%~100.0%	0.0%	☆
FA.13	Multi-segment instruction 13	-100.0%~100.0%	0.0%	☆
FA.14	Multi-segment instruction 14	-100.0%~100.0%	0.0%	☆
FA.15	Multi-segment instruction 15	-100.0%~100.0%	0.0%	☆

Function Code	Name	Setting Range	Factory Default	Change
FA.16	Multi-segment instruction 0-given mode	0: Function code FA.00 given 1: AII 5: PID 6: Preset frequency (F0.09) given, UP/DOWN can be modified	0	☆
FA.17	Simple PLC operation mode	0: Stop after a single run 1: Retain final value after a single run 2: Continuously loop	0	☆
FA.18	Simple PLC power-down memory selection	Units digit: Power-off memory selection 0: No memory after power-off 1: Memory after power-off Tens digit: Power-off memory selection 0: No memory after power-off 1: Memory after power-off	00	☆
FA.19	Simple PLC Segment 0 Running Time	0.0s (h) ~6553.5s (h)	0.0s (h)	☆
FA.20	Simple PLC Segment 0 Acceleration/Deceleration Time Selection	0~3	0	☆
FA.21	Simple PLC Segment 1 Running Time	0.0s (h) ~6553.5s (h)	0.0s (h)	☆
FA.22	Simple PLC Segment 1 Acceleration/Deceleration Time Selection	0~3	0	☆
FA.23	Simple PLC Segment 2 Running Time	0.0s (h) ~6553.5s (h)	0.0s (h)	☆
FA.24	Simple PLC Segment 2 Acceleration/Deceleration Time Selection	0~3	0	☆
FA.25	Simple PLC Segment 3 Running Time	0.0s (h) ~6553.5s (h)	0.0s (h)	☆
FA.26	Simple PLC Segment 3 Acceleration/Deceleration Time Selection	0~3	0	☆
FA.27	Simple PLC Segment 4 Running Time	0.0s (h) ~6553.5s (h)	0.0s (h)	☆
FA.28	Simple PLC Segment 4 Acceleration/Deceleration Time Selection	0~3	0	☆
FA.29	Simple PLC Segment 5 Running Time	0.0s (h) ~6553.5s (h)	0.0s (h)	☆
FA.30	Simple PLC Segment 5 Acceleration/Deceleration Time Selection	0~3	0	☆
FA.31	Simple PLC Segment 6 Running Time	0.0s (h) ~6553.5s (h)	0.0s (h)	☆
FA.32	Simple PLC Segment 6 Acceleration/Deceleration Time Selection	0~3	0	☆
FA.33	Simple PLC Segment 7 Running Time	0.0s (h) ~6553.5s (h)	0.0s (h)	☆
FA.34	Simple PLC Segment 7 Acceleration/Deceleration Time Selection	0~3	0	☆
FA.35	Simple PLC Segment 8 Running Time	0.0s (h) ~6553.5s (h)	0.0s (h)	☆
FA.36	Simple PLC Segment 8 Acceleration/Deceleration Time Selection	0~3	0	☆
FA.37	Simple PLC Segment 9 Running Time	0.0s (h) ~6553.5s (h)	0.0s (h)	☆
FA.38	Simple PLC Segment 9 Acceleration/Deceleration Time Selection	0~3	0	☆
FA.39	Simple PLC Segment 10 Running Time	0.0s (h) ~6553.5s (h)	0.0s (h)	☆
FA.40	Simple PLC Segment 10 Acceleration/Deceleration Time Selection	0~3	0	☆
FA.41	Simple PLC Segment 11 Running Time	0.0s (h) ~6553.5s (h)	0.0s (h)	☆
FA.42	Simple PLC Segment 11 Acceleration/Deceleration Time Selection	0~3	0	☆
FA.43	Simple PLC Segment 12 Running Time	0.0s (h) ~6553.5s (h)	0.0s (h)	☆
FA.44	Simple PLC Segment 12 Acceleration/Deceleration Time Selection	0~3	0	☆
FA.45	Simple PLC Segment 13 Running Time	0.0s (h) ~6553.5s (h)	0.0s (h)	☆
FA.46	Simple PLC Segment 13 Acceleration/Deceleration Time Selection	0~3	0	☆
FA.47	Simple PLC Segment 14 Running Time	0.0s (h) ~6553.5s (h)	0.0s (h)	☆
FA.48	Simple PLC Segment 14 Acceleration/Deceleration Time Selection	0~3	0	☆
FA.49	Simple PLC Segment 15 Running Time	0.0s (h) ~6553.5s (h)	0.0s (h)	☆
FA.50	Simple PLC Segment 15 Acceleration/Deceleration Time Selection	0~3	0	☆
FA.51	Simple PLC running time unit	0: s 1: h	0	☆

Function Code	Name	Setting Range	Factory Default	Change
<b>Fb Group Faults and Protection</b>				
Fb.00	Motor overload protection selection	0: Prohibited 1: Allowed	1	☆
Fb.01	Motor overload protection gain	0.20~10.00	1.00	☆
Fb.02	Motor overload warning coefficient	50%~100%	80%	☆
Fb.03	Overvoltage stall gain	0~100	30	☆
Fb.04	Overvoltage stall protection voltage	200.0V~810.0V	220V: 380.0V 380V: 760.0V	☆
Fb.05	Overvoltage stall gain	0~100	20	☆
Fb.06	Overvoltage stall protection current	100%~200%	150%	☆
Fb.07	Power-on short-circuit protection selection	0: Invalid 1: Valid	1	☆
Fb.08	Automatic fault reset count	0~20	0	☆
Fb.09	lt Y-action selection during automatic fault reset	0: No action 1: Action	0	☆
Fb.10	Automatic fault reset interval	0.1s~100.0s	1.0s	☆
Fb.12	Output phase loss protection selection	0: Prohibited 1: Allowed	1	☆
Fb.42	Energy-consumption braking starting voltage	200.0V~810.0V	700.0V	☆
<b>FC Group Fault Record Group</b>				
FC.00	Previous (most recent) fault type	0: No fault 2: Acceleration overcurrent 3: Deceleration overcurrent 4: Constant speed overcurrent 5: Acceleration overvoltage 6: Deceleration overvoltage 7: Constant speed overvoltage 8: Control power supply overvoltage (constant speed overvoltage) 9: Undervoltage 10: Inverter overload 11: Motor overload 12: Input phase loss 13: Output phase loss 14: Module overheating 15: External fault 16: Communication abnormality 18: Current detection abnormality 21: Parameter read/write abnormality 22: Inverter hardware abnormality 23: Motor short circuit to ground 27: User-defined fault 1 28: User-defined fault 2 29: Power-on time reached 30: Load drop 31: PID feedback lost during operation	-	●
FC.01	Previous two fault types		-	●

## 5.2 Summary Table of Monitoring Parameters

Table 5-2 Summary of Monitoring Parameters

Function Code	Name	Smallest unit	Mailing address
<b>L0 group basic monitoring parameters</b>			
L0.00	Operating Frequency (Hz)	0.01Hz	7000H
L0.01	Set Frequency (Hz)	0.01Hz	7001H
L0.02	Bus Voltage (V)	0.1V	7002H
L0.03	Output Voltage (V)	1V	7003H
L0.04	Output Current (A)	0.01A	7004H
L0.05	Output Power (kW)	0.1kW	7005H
L0.06	Output Torque (%)	0.1%	7006H
L0.07	X Input Status	1	7007H
L0.08	Y Output Status	1	7008H
L0.09	All Voltage (V)	0.01V	7009H
L0.11	External Keyboard Potentiometer Voltage (V)	0.01V	700BH
L0.12	Count Value	1	700CH
L0.13	Length Value	1	700DH
L0.14	Load Speed Display	1	700EH
L0.15	PID Setting	0	700FH
L0.16	PID Feedback	0	7010H
L0.28	Communication Setting Value	0.1%	701CH

## 6 ) Fault diagnosis and countermeasures

Table 6-1 Fault Diagnosis and Countermeasures

Fault Name	Operation Panel Display	Fault Cause Troubleshooting	Fault Handling Measures
Accelerating overcurrent	E002	<ol style="list-style-type: none"> <li>1. Grounding or short circuit in the inverter output circuit</li> <li>2. Vector control mode without parameter identification</li> <li>3. Acceleration time too short</li> <li>4. Manual torque boost or inappropriate V/F curve</li> <li>5. Low voltage</li> <li>6. Starting a rotating motor</li> <li>7. Sudden load application during acceleration</li> <li>8. Inverter undersized</li> </ol>	<ol style="list-style-type: none"> <li>1. Troubleshoot external faults</li> <li>2. Identify motor parameters</li> <li>3. Increase acceleration time</li> <li>4. Adjust manual torque boost or V/F curve</li> <li>5. Adjust voltage to normal range</li> <li>6. Select speed tracking start or wait for the machine to stop before starting</li> <li>7. Eliminate sudden load increases</li> <li>8. Select a frequency converter with a higher power rating</li> </ol>
Decelerating overcurrent	E003	<ol style="list-style-type: none"> <li>1. The inverter output circuit has a grounding or short circuit.</li> <li>2. The control mode is vector and parameter identification has not been performed.</li> <li>3. The deceleration time is too short.</li> <li>4. The voltage is too low.</li> <li>5. A sudden load is applied during deceleration.</li> <li>6. No braking unit or braking resistor is installed.</li> </ol>	<ol style="list-style-type: none"> <li>1. Troubleshoot external faults</li> <li>2. Identify motor parameters</li> <li>3. Increase deceleration time</li> <li>4. Adjust voltage to normal range</li> <li>5. Eliminate sudden load changes</li> <li>6. Install braking unit and resistor</li> </ol>
Constant-speed overcurrent	E004	<ol style="list-style-type: none"> <li>1. The inverter output circuit has a grounding or short circuit.</li> <li>2. The control mode is vector and parameter identification has not been performed.</li> <li>3. The voltage is too low.</li> <li>4. Is there a sudden load increase during operation?</li> <li>5. The selected inverter is too small.</li> </ol>	<ol style="list-style-type: none"> <li>1. Troubleshoot external faults</li> <li>2. Identify motor parameters</li> <li>3. Adjust voltage to normal range</li> <li>4. Eliminate sudden load changes</li> <li>5. Select a higher power inverter</li> </ol>
Accelerating overvoltage	E005	<ol style="list-style-type: none"> <li>1. Input voltage is too high</li> <li>2. External force is driving the motor during acceleration</li> <li>3. Acceleration time is too short</li> <li>4. No braking unit or braking resistor is installed.</li> </ol>	<ol style="list-style-type: none"> <li>1. Adjust the voltage to the normal range.</li> <li>2. Remove additional power or install a braking resistor.</li> <li>3. Increase the acceleration time.</li> <li>4. Install a braking unit and resistor.</li> </ol>
Decelerating overvoltage	E006	<ol style="list-style-type: none"> <li>1. Input voltage is too high</li> <li>2. External force is driving the motor during deceleration</li> <li>3. Deceleration time is too short</li> <li>4. A braking unit and braking resistor have been added.</li> </ol>	<ol style="list-style-type: none"> <li>1. Adjust the voltage to the normal range.</li> <li>2. Remove additional power or install a braking resistor.</li> <li>3. Increase the deceleration time.</li> <li>4. Install a braking unit and resistor.</li> </ol>
Constant speed overvoltage	E007	<ol style="list-style-type: none"> <li>1. Input voltage is too high</li> <li>2. External force is driving the motor during operation.</li> </ol>	<ol style="list-style-type: none"> <li>1. Adjust the voltage to the normal range.</li> <li>2. Remove additional power or install a braking resistor.</li> </ol>
Control power supply failure	E008	<ol style="list-style-type: none"> <li>1. The input voltage is not within the range specified in the standard.</li> </ol>	<ol style="list-style-type: none"> <li>1. Adjust the voltage to the specified range.</li> </ol>
Undervoltage fault	E009	<ol style="list-style-type: none"> <li>1. Momentary power outage</li> <li>2. Inverter input voltage outside the specified range</li> <li>3. Abnormal bus voltage</li> <li>4. Abnormal rectifier bridge and buffer resistor</li> <li>5. Driver board malfunction</li> <li>6. Control board malfunction</li> </ol>	<ol style="list-style-type: none"> <li>1. Reset fault</li> <li>2. Adjust voltage to normal range</li> <li>3. Seek technical support</li> <li>4. Seek technical support</li> <li>5. Seek technical support</li> <li>6. Seek technical support</li> </ol>
Inverter overload	E010	<ol style="list-style-type: none"> <li>1. Is the load too large or is the motor stalled?</li> <li>2. Is the selected frequency converter too small?</li> </ol>	<ol style="list-style-type: none"> <li>1. Reduce the load and check the condition of the motor and machinery.</li> <li>2. Select a frequency converter with a higher power rating.</li> </ol>
Motor overload	E011	<ol style="list-style-type: none"> <li>1. Is the motor protection parameter Fb.01 set appropriately?</li> <li>2. Is the load too large or is the motor stalled?</li> <li>3. Is the selected frequency converter too small?</li> </ol>	<ol style="list-style-type: none"> <li>1. Set this parameter correctly.</li> <li>2. Reduce the load and check the condition of the motor and machinery.</li> <li>3. Select a frequency converter with a higher power rating.</li> </ol>
Output phase loss	E013	<ol style="list-style-type: none"> <li>1. Inverter to motor lead wire malfunction</li> <li>2. Inverter three-phase output imbalance during motor operation</li> <li>3. Driver board malfunction</li> <li>4. Module malfunction</li> </ol>	<ol style="list-style-type: none"> <li>1. Troubleshoot external faults.</li> <li>2. Check if the motor's three-phase windings are normal and troubleshoot any faults.</li> <li>3. Seek technical support.</li> <li>4. Seek technical support.</li> </ol>
Module overheating	E014	<ol style="list-style-type: none"> <li>1. Ambient temperature too high</li> <li>2. Air duct blockage</li> <li>3. Fan malfunction</li> <li>4. Module thermistor malfunction</li> <li>5. Inverter module malfunction</li> </ol>	<ol style="list-style-type: none"> <li>1. Lower the ambient temperature</li> <li>2. Clean the air ducts</li> <li>3. Replace the fan</li> <li>4. Replace the thermistor</li> <li>5. Replace the inverter module</li> </ol>
External device failure	E015	<ol style="list-style-type: none"> <li>1. Input external fault signals via multi-function terminal X</li> <li>2. Input external fault signals via virtual I/O function</li> </ol>	<ol style="list-style-type: none"> <li>1. Reset Operation</li> <li>2. Reset Operation</li> </ol>
Communication failure	E016	<ol style="list-style-type: none"> <li>1. The host computer is malfunctioning.</li> <li>2. The communication cable is faulty.</li> <li>3. The communication parameter Fd group is incorrectly set.</li> </ol>	<ol style="list-style-type: none"> <li>1. Check the host computer wiring.</li> <li>2. Check the communication connection cable.</li> <li>3. Correctly set the communication parameters.</li> </ol>
Current detection failure	E018	<ol style="list-style-type: none"> <li>1. Check for Hall effect device malfunctions</li> <li>2. Check for driver board malfunctions</li> </ol>	<ol style="list-style-type: none"> <li>1. Replace the Hall effect sensor</li> <li>2. Replace the driver board</li> </ol>
EEPROM read/write failure	E021	EEPROM chip damaged	Replace main control board
Short circuit to ground failure	E023	Motor short circuit to ground	Replace the cable or motor

User-defined fault 1	E027	1. Input the signal for user-defined fault 1 via multi-function terminal X. 2. Input the signal for user-defined fault 1 via virtual I/O function.	1. Reset Operation 2. Reset Operation
Accumulated running time reached fault	E026	Accumulated running time reaches the set value	Use the parameter initialization function to clear the recorded information.
User-defined fault 2	E028	1. Input the signal for user-defined fault 2 via multi-function terminal X. 2. Input the signal for user-defined fault 2 via virtual I/O function.	1. Reset Operation 2. Reset Operation
Accumulated power-on time reached fault	E029	1. The cumulative power-on time has reached the set value.	1. Use the parameter initialization function to clear the recorded information.
Load failure	E030	1. The inverter operating current is less than Fb.31	1. Confirm whether the load is disconnected or whether the parameter settings of Fb.31 and Fb.32 match the actual operating conditions.
Runtime PID feedback loss failure	E031	1. PID feedback is less than the F9.26 setpoint.	1. Check the PID feedback signal or set F9.26 to a suitable value.
Wave-by-wave current limiting failure	E040	1. Is the load too large or is the motor stalled? 2. Is the selected frequency converter too small?	1. Reduce the load and check the condition of the motor and machinery. 2. Select a frequency converter with a higher power rating.
Password protected	-----	1. The frequency converter has been set with a user password.	1. Enter the correct user password or contact the agent.

## 7 ) Communication

### 7.1 Parameter Address

For parameter data in groups F0~FE and A0~AC, the high eight bits of the communication address are the function group number, and the low eight bits are the parameter's sequence number in the function group converted to hexadecimal. For example, parameter FA.17 has a communication address of FA11H, where FA represents the parameter of group FA, and 11 represents the parameter's value after converting the decimal function code sequence number 17 to hexadecimal; parameter AC.27 has a communication address of AC1BH, where AC represents the parameter of group AC, and 1B represents the parameter's value after converting the function group sequence number 27 to hexadecimal; the communication addresses for group L monitoring parameters are shown in the parameter table above.

### 7.2 Control Parameter Address

#### 7.2.1 Communication Setting Value

Communication Address: 1000H. When the host computer sets this communication address value, its data range is -10000 to 10000, corresponding to a relative given value of -100.0% to 100.00%.

#### 7.2.2 Control Commands

Table 7-1 Control Commands

Type	Communication Address	Read/Write Range Description
Control command input (write-only)	2000	0001: Forward rotation 0002: Reverse rotation 0003: Forward jogging 0004: Reverse jogging 0005: Free stop 0006: Deceleration stop 0007: Fault reset
Status read (read-only)	3000	0001: Forward rotation 0002: Reverse rotation 0003: Shutdown
Digital output terminal control (write-only)	2001	BIT2: TA/TC Output Control
Analog output AO1 control (write-only)	2002	0~7FFF represents 0%~100%.

Table 7-2

Parameter address	Parameter description	Parameter address	Parameter description
1000H	*Communication settings (decimal) -10000~10000	1010H	PID Setting
1001H	Operating frequency	1011H	PID Feedback
1002H	Bus voltage	1012H	PLC Steps
1003H	Output voltage	1013H	Reserved
1004H	Output current	1014H	Feedback speed, in units of 0.1 Hz
1005H	Output power	1015H	Remaining runtime
1006H	Output torque	1016H	All voltage before calibration
1007H	Operating speed	1017H	External keyboard potentiometer voltage before calibration
1008H	X Input Flag	1018H	Reserved
1009H	Y Output Flag	1019H	Motor Speed
100AH	All Voltage	101AH	Current Power-On Time
100BH	Reserved	101BH	Current Running Time
100CH	External Potentiometer Voltage	101CH	Reserved
100DH	Count Value Input	101DH	Communication settings
100EH	Length Value Input	101EH	Reserved
100FH	Load Speed	101FH	Main frequency X display
-	-	1020H	Auxiliary frequency Y display

### 7.2.3 Fault

Table 7-3 Faults

Inverter fault address	Inverter fault information	
8000H	0000: No fault 0001: Reserved 0002: Acceleration overcurrent 0003: Deceleration overcurrent 0004: Constant speed overcurrent 0005: Acceleration overvoltage 0006: Deceleration overvoltage 0007: Constant speed overvoltage 0008: Buffer resistor overload fault 0009: Undervoltage fault 000A: Inverter overload 000B: Motor overload 000C: Input phase loss 000D: Output phase loss 000E: Module overheating 000F: External fault	0010: Communication Error 0011: Input Line Error 0012: Current Detection Fault 0013: Motor Self-Learning Fault 0015: Parameter Read/Write Error 0016: Inverter Hardware Fault 0017: Motor Short Circuit to Ground Fault 0018: Reserved 0019: Reserved 001A: Reserved 001B: User-defined Fault 1 001C: User-defined Fault 2 001D: Power-on Time Expired 001E: Load Drop 001F: PID Feedback Lost During Operation 0028: Fast Current Limiting Timeout Fault

Communication Fault Address	Fault Function Description
8001	0000: No fault 0001: Incorrect password 0002: Incorrect command code 0003: CRC check error 0004: Invalid address 0005: Invalid parameter 0006: Invalid parameter change 0007: System locked

### 8) Other

Product specifications and details are subject to change without notice.  
For any questions, please contact your agent or distributor.

